

**CAMINO REAL REGIONAL MOBILITY AUTHORITY
BOARD RESOLUTION**

WHEREAS, the Camino Real Regional Mobility Authority (CRRMA) entered into a construction contract dated October 17, 2016 (Contract) with Horizonte Construction 1, Ltd. (Contractor) for the construction of the Rojas Drive Improvements Project (Project);

WHEREAS, during construction, the Contractor requested the ability to install certain manholes using a pre-cast method, rather than the cast-in-place method required by the Project's plans; and

WHEREAS, there is no cost or time impact to the Project for the requested alternate construction method, the County of El Paso has approved this approach and the parties therefore desire to execute Change Order No. 1 to the Contract, for such change in process;

NOW, THEREFORE, BE IT RESOLVED BY THE CAMINO REAL REGIONAL MOBILITY AUTHORITY:

THAT the Executive Director be authorized to execute Change Order No. 1 with Horizonte Construction 1, Ltd., to permit certain manholes to be cast-in-place on the Rojas Drive Improvements Project.

PASSED AND APPROVED THIS 6TH DAY OF JUNE 2017.

**CAMINO REAL REGIONAL
MOBILITY AUTHORITY**

Joe D. Wardy, Vice Chair

ATTEST:

Joe R. Fernandez, Board Secretary

APPROVED AS TO CONTENT:

Raymond L. Telles
Executive Director

CONSTRUCTION CONTRACT CHANGE ORDER NUMBER #1

1. CONTRACTOR: Horizone Construction 1, Ltd.

2. Change Order Work Limits: Sta. 21+14 to Sta. 23+90

3. Type of Change (on federal-aid non-exempt projects): Minor (Major/Minor)

4. Describe the change and the reason for the change order. When necessary, include exceptions to this agreement.

This is a no cost change order. No additional time will be added to the contract for completing the work.

During Construction activities, the Contractor installed two manholes [MH-7 (STA 21+14) & MH-9 (25+60)] as pre-cast instead of cast-in-place. Contractor has been notified both manholes will be paid as cast-in-place per bid unit price, and no additional time will be awarded.

5. New or revised plan sheet(s) are attached and numbered:

Each signatory hereby warrants that each has the authority to execute this Change Order.

CCSJ:	<u>N/A</u>
Project:	<u>Rojas Dr Improvement</u>
Highway:	<u>CS (Rojas Drive)</u>
County:	<u>El Paso</u>
District:	<u>ELP</u>
Contract Number:	<u>N/A</u>

<p>By signing this change order, the contractor agrees to waive any and all claims for additional compensation due to any and all other expenses; additional changes for time, overhead and profit; or loss of compensation as a result of this change. Further, the contractor agrees that this agreement is made in accordance with Item 4 and the Contract. Exceptions should be noted in the response for #5 above.</p>	<p>The following information must be provided</p>
	<p>Time Ext. #0 : <u>0</u> Days added on this C.O.#1: _____</p> <p>Amt. added by this change order: <u>No Cost CO</u></p>
<p>THE CONTRACTOR Date <u>5/30/17</u></p> <p>By <u>[Signature]</u></p> <p>Typed/Printed Name <u>LUIS R DE STEFANO</u></p> <p>Typed/Printed Title <u>VICE PRESIDENT</u></p>	

CAMINO REAL REGIONAL MOBILITY AUTHORITY

Executed for and approved by the Camino Real Regional Mobility Authority for the purpose and effect of activating and/or carrying out the orders, established policies or work programs heretofore approved and authorized by the Texas Transportation Commission.

Signature Date

Typed/Printed Name and Title

LIST OF ATTACHMENTS

Approved shop drawings for MH-7 & MH-9

**SHOP DRAWING REVIEW
HUITT-ZOLLARS, INC.**

A/E REVIEW	RESPONSE REQUIRED OF CONTRACTOR
<input checked="" type="checkbox"/> Reviewed - No Exceptions	<input checked="" type="checkbox"/> No Response Required
<input type="checkbox"/> Exceptions as Noted	<input type="checkbox"/> Confirm in Writing
<input type="checkbox"/> Rejected	<input type="checkbox"/> Revise and Resubmit
<input type="checkbox"/> Not Required for Review	<input type="checkbox"/> Submit Specified Item

This review is only for general conformance with the design concept and the information given in the Construction Documents. Corrections or comments made on the shop drawings during this review do not relieve the Contractor from compliance with the requirements of the plans and specifications and applicable laws, codes and regulations. Review of a specific item shall not include review of an assembly of which the item is a component. The Contractor is responsible for: dimensions to be confirmed and correlated at the jobsite; information that pertains solely to the fabrication processes or to the means, methods, techniques, sequences and procedures of construction; coordination of the Work with that of all other trades; and performing all Work in a safe and satisfactory manner.

Project Number: Rojas Dr. Spec. Number: Inlet & MH's
By: Roxann Rin, PE Date: 1/29/17

72" I.D. MANHOLE

MH-7 STA 21+14

*** CAST IN PLACE ***

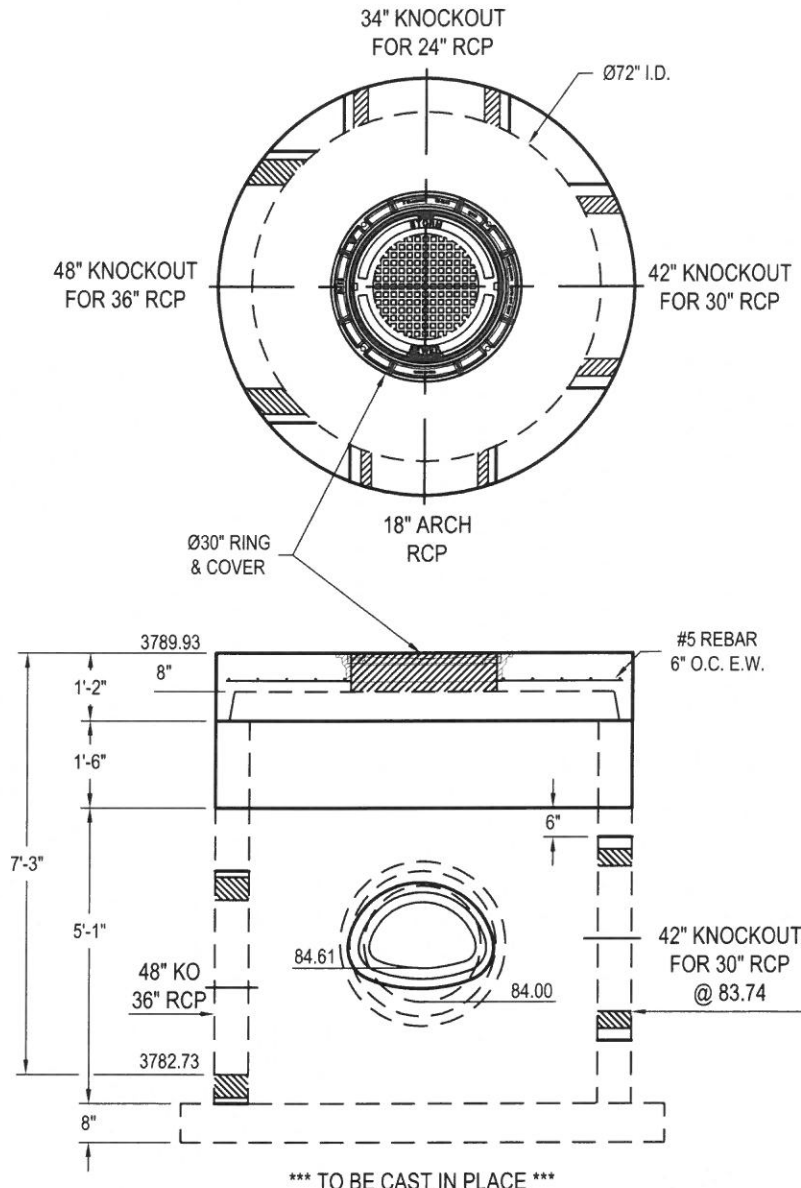

WESTERN PRECAST CONCRETE, INC.
"SHOP DRAWING"

X

CUSTOMER APPROVAL TO PRODUCE

WESTERN

PRECAST CONCRETE INC.

QUALITY PRODUCTS AND SERVICE SINCE 1946

CONTRACTOR:	ITEM NO:
HORIZONE CONSTRUCTION	72" I.D. MANHOLE
JOB NAME:	SLS/PRSK: DATE:
ROJAS DRIVE IMPROVEMENT R.A.	11.03.2016

72" I.D. MANHOLE

MH-9 STA 25+60.00

*** CAST IN PLACE ***

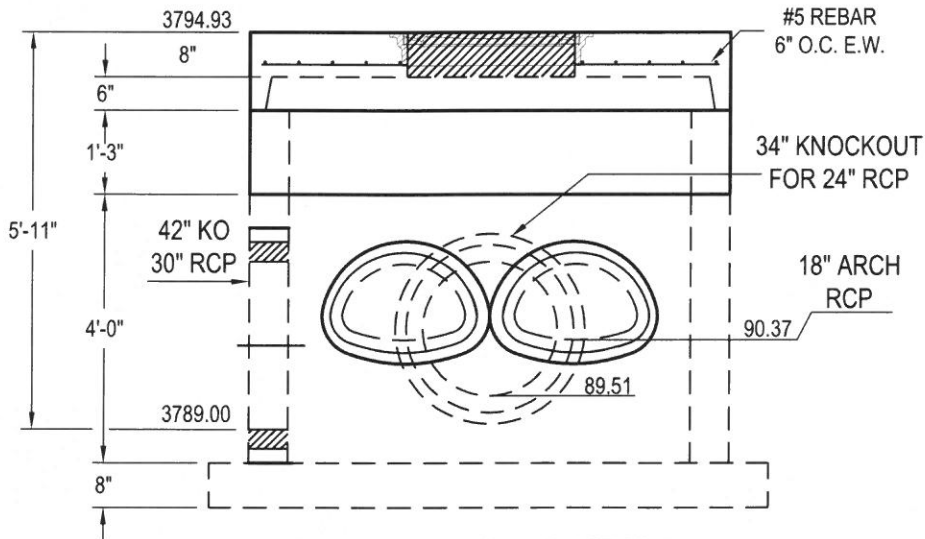
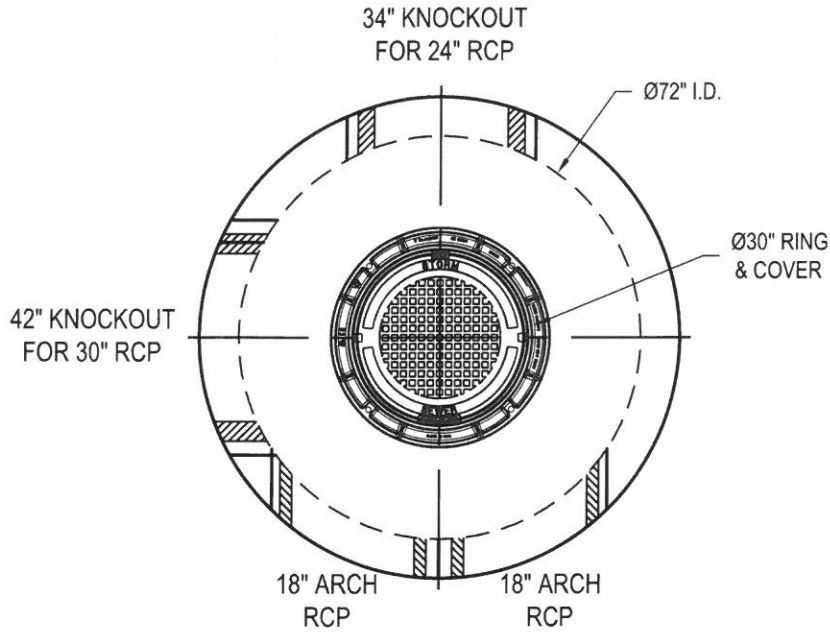

WESTERN PRECAST CONCRETE, INC.
"SHOP DRAWING"

X

CUSTOMER APPROVAL TO PRODUCE

WESTERN
PRECAST CONCRETE INC.
QUALITY PRODUCTS AND SERVICE SINCE 1946

CONTRACTOR:	ITEM NO:
HORIZONE CONSTRUCTION	72" I.D. MANHOLE
JOB NAME:	SLS/PRSN: DATE:
ROJAS DRIVE IMPROVEMENT	R.A. 12.09.2016

CAMINO REAL REGIONAL MOBILITY AUTHORITY

CONSTRUCTION CONTRACT CHANGE ORDER NUMBER 1

Third Party Funding Notification Sheet

This form is used when the subject change order involves funding by a source other than CRRMA, and involves third parties who are providing funding under an Advance Funding Agreement or Donation Agreement.

1. Outside funding provided by:

County of El Paso

(Outside Entity's Legal Name)

2. Type of outside funding agreement for this change:

Existing Amended New

[Check one]

3. Indicate the type and amount of funding:

Fixed Price (Lump Sum) (Estimated Amount) _____

Actual Cost _____

(a) Contract Items (Bid Items): _____

TOTAL

\$0.00 _____

CCSJ:	<u>N/A</u>
	<u>Rojas Dr Improvements</u>
	<u>Project</u>
Highway:	<u>CS(Rojas Dr)</u>
County:	<u>El Paso</u>
District:	<u>N/A</u>

Use as needed:

I hereby acknowledge notification of the modifications covered by this Change Order.

Date _____

By _____

Typed/Printed Name _____

Typed/Printed Title _____

* The percentage (%) for E&C (Engineering and Contingencies) charges varies from project to project depending on the contract amount of the project. Projects with a higher contract amount will have a lower rate of E&C charge. For a specific project, E&C rate (%) can be derived from the cost of "Engineering and Contingencies" in the "Estimated Cost" of the project.

** Use the statewide district rate as established by Finance Division each year. This line 3 (c) is for Service Project only, unless otherwise specified in the Advance Funding Agreement. See Stand Alone Manual Notice 98-2 for instructions.

Funding for this Change Order has been arranged:

Norma Lucia Palacios

Representative

Typed/Printed Name:

NORMA LUCIA PALACIOS

Date

6/1/2017

Contact/Help